

2 MODULAR

SINGLE PHASE DIN RAIL WATT HOUR METER

INTRODUCTION

Modular DIN Rail Products offer a wide range of functions to be integrated in electrical installations with significant benefits for the user, we have complete range of DIN-mounted electricity Meters together with communication options. It is designed for high level performance and are safe and fast to install.

The meters are available in several configurations to suite many applications, with the increasing energy cost, measuring of the electricity consumption is getting more and more important, If you can identify where you have used you are one step closer to reducing your energy cost, Now start to make energy usage smarter.

FUNCTIONS

- ◆ Meter case: ABS + PC anti flaming, environment friendly material
- ◆ Dimension: 35.5mm width. 88.5mm length, 72mm height
- ◆ Display: LCD display 6+1digits
- ◆ Standard configuration pulse output passive (polarity)
- ◆ Forward active energy and reverse active energy measurement
- ◆ Directly connect operation, Maximum 80A (standard) ;
- ◆ Approved by international standard IEC62052-11, IEC62053-21

● OPTIONAL FUNCTION

1. Communicate RS485 Modbus RTU protocol, baud rate: 1200~9600bps
2. Voltage (V); Current (A); Frequency (Hz); Power (KW); Power factor (COS)



TECHNICAL PARAMETERS

Model NO.	DDM65SC; DDM65SCR
Installation	35mm Din Rail Mounted
Accuracy	Class 1.0
Rated voltage	AC 110V, 220V, 230V, 240V
voltage range	0.8 ~ 1.2Un
Rated current	5(30)A, 10(40)A, 15(60)A, 20(80)A
Operation current range	0.05Ib ~ Imax
Starting current	0.4%Ib
Rated frequency	50Hz or 60 Hz
Power consumption	2W / 10VA
Impulse constant	1600imp/kWh
Relative humidity	≤ 85%
Operation temperature	-10°C ~ +60°C
Insulation capabilities	AC voltage withstand 2kV for 1 minute Impulse voltage withstand 4kV - 1.2/50μs waveform

DIMENSION

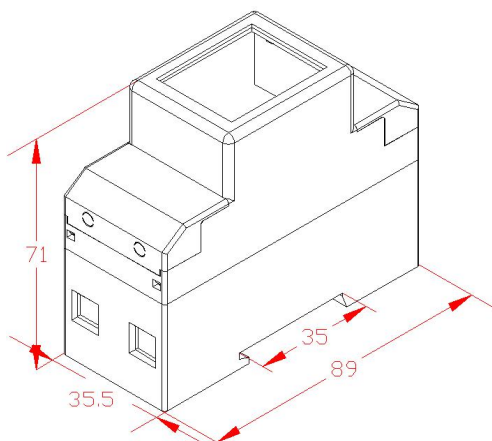

WIRING DIAGRAM

